

② DETAIL

NOTES:
3/4" EXT. TYPE PLYWOOD OPTIONAL FOR INTERIOR SIDING

12'-0" SHEETS OF CORRUGATED ALUM. (.019) OR GALV. STEEL ROOFING (26 GA.)
CENTER PANEL TO BE TRANSLUCENT PLASTIC

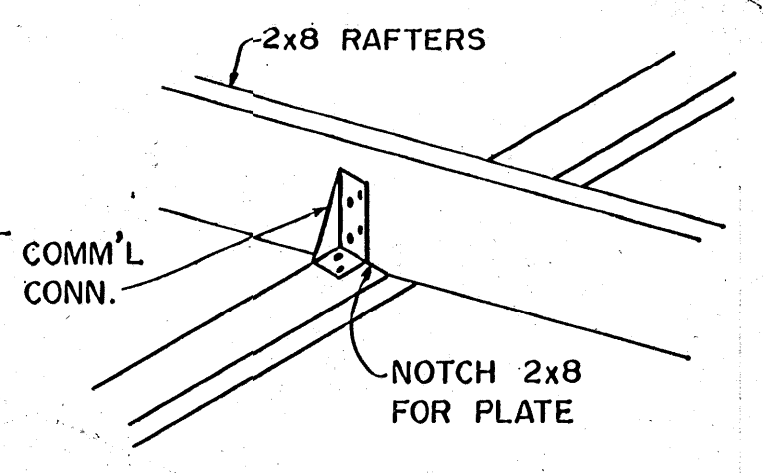

③ DETAIL

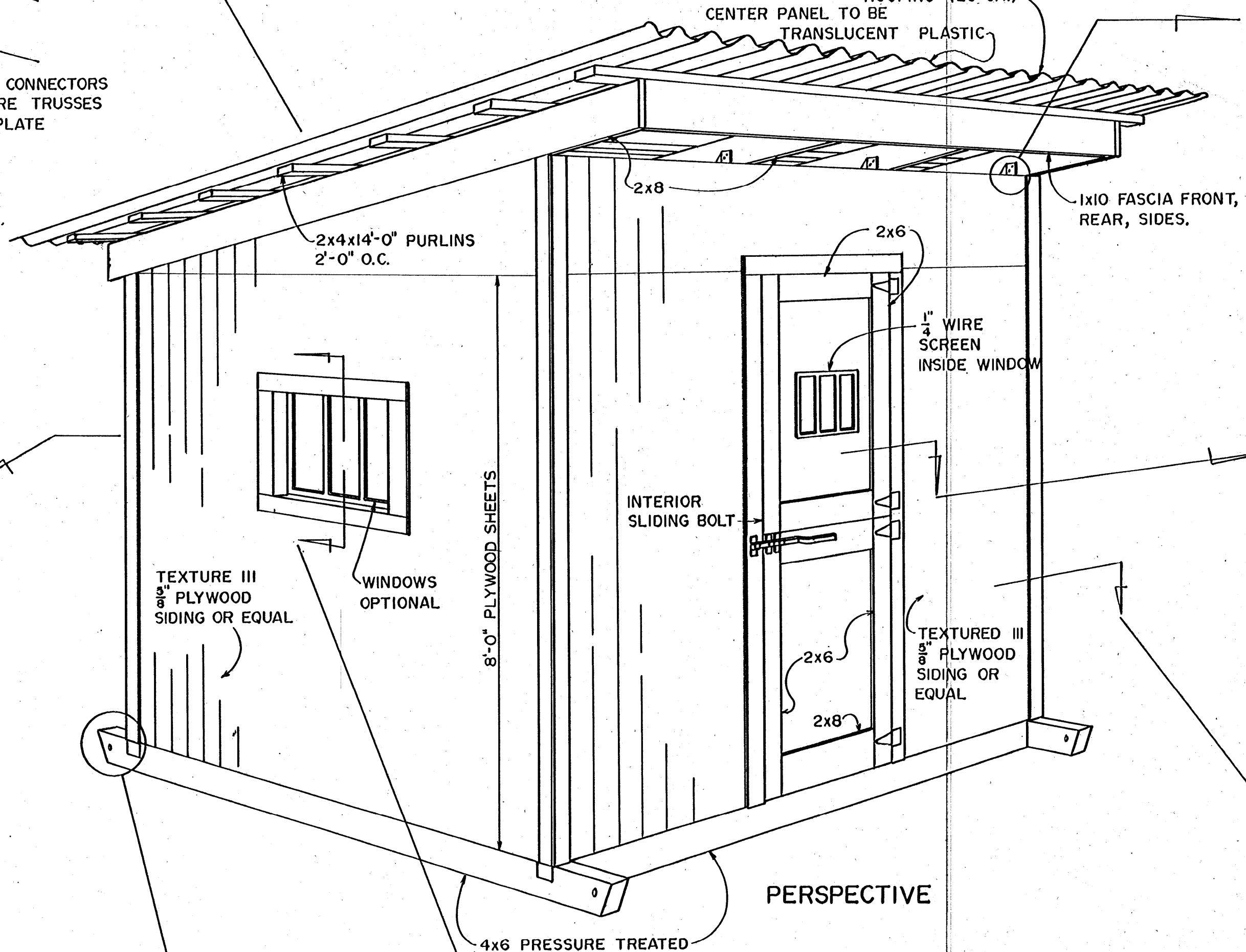

PERSPECTIVE

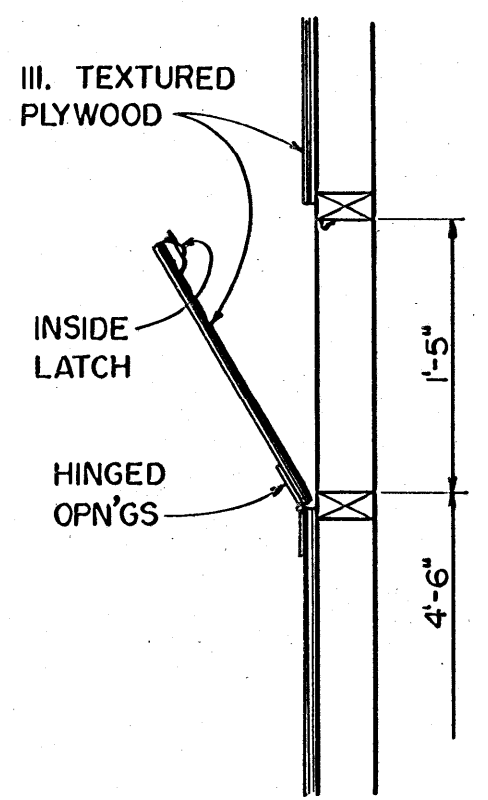

① DETAIL OF TWO OPN'GS AT REAR

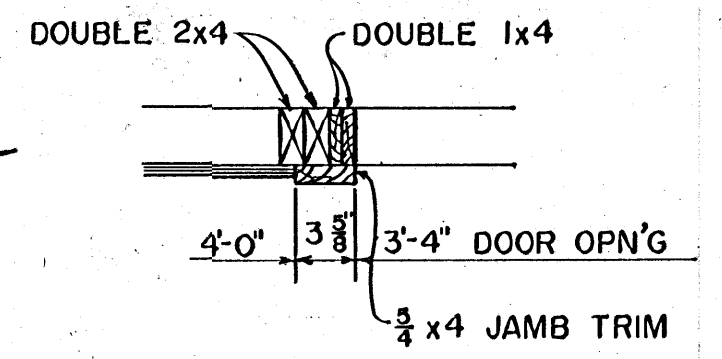

④ SECTION AT DOOR

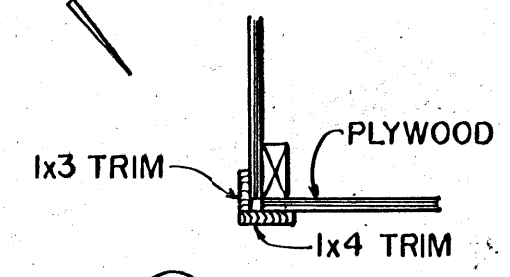

⑤ DETAIL

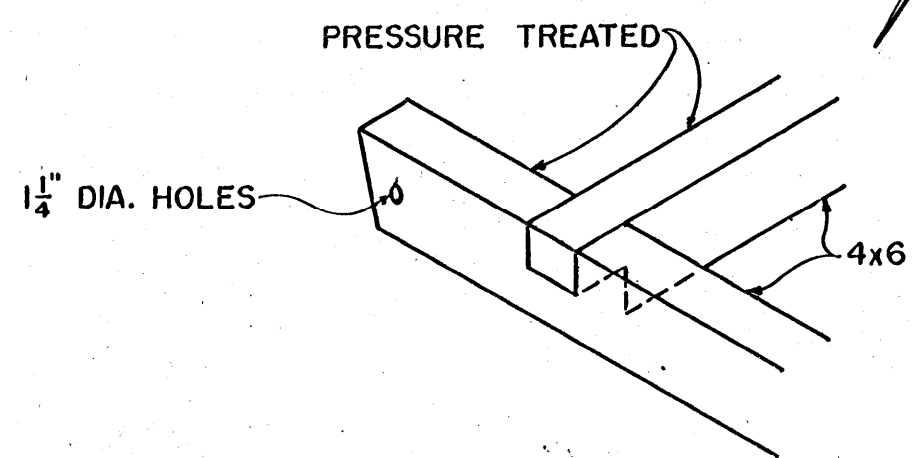

⑦ DETAIL

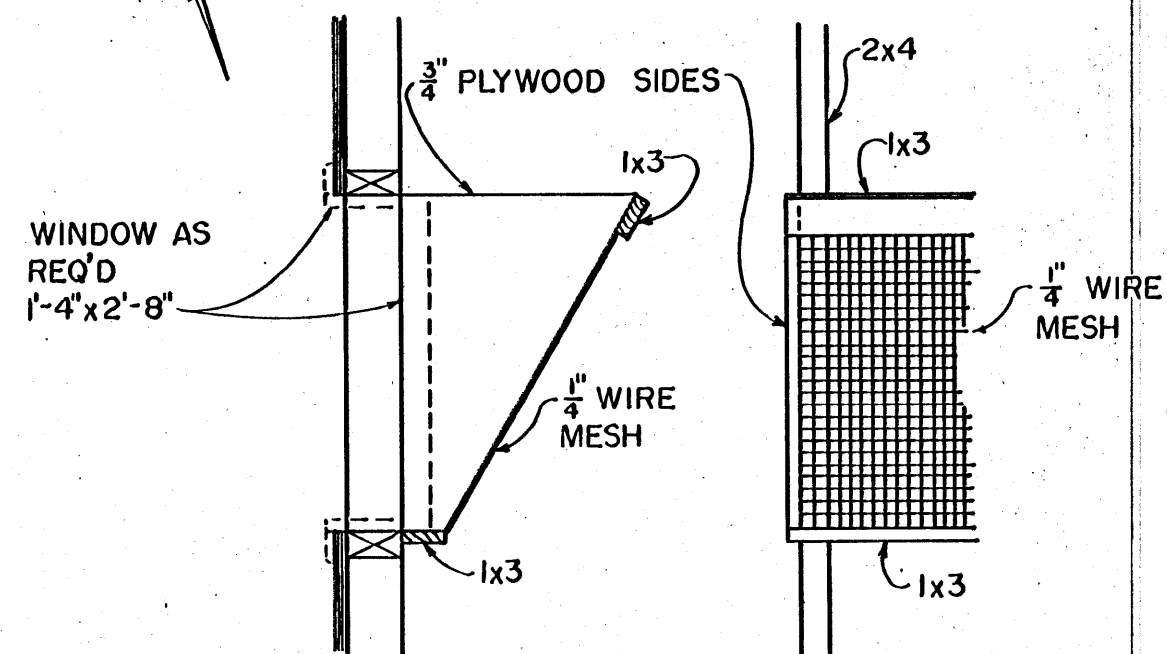

⑥ WINDOW GUARD SECTION

PARTIAL ELEV.

SCALE: 1" = 1'-0" UNLESS OTHERWISE STATED

COOPERATIVE EXTENSION WORK IN AGRICULTURE AND HOME ECONOMICS
STATE OF MISSISSIPPI
MISSISSIPPI STATE UNIVERSITY
AND
UNITED STATES DEPARTMENT OF AGRICULTURE COOPERATING

PORTABLE STABLE FOR A HORSE

N.J. '69	6082	SHEET 1 OF 2
----------	------	--------------

NOTE: BASED ON N.J. PLAN NO. 150

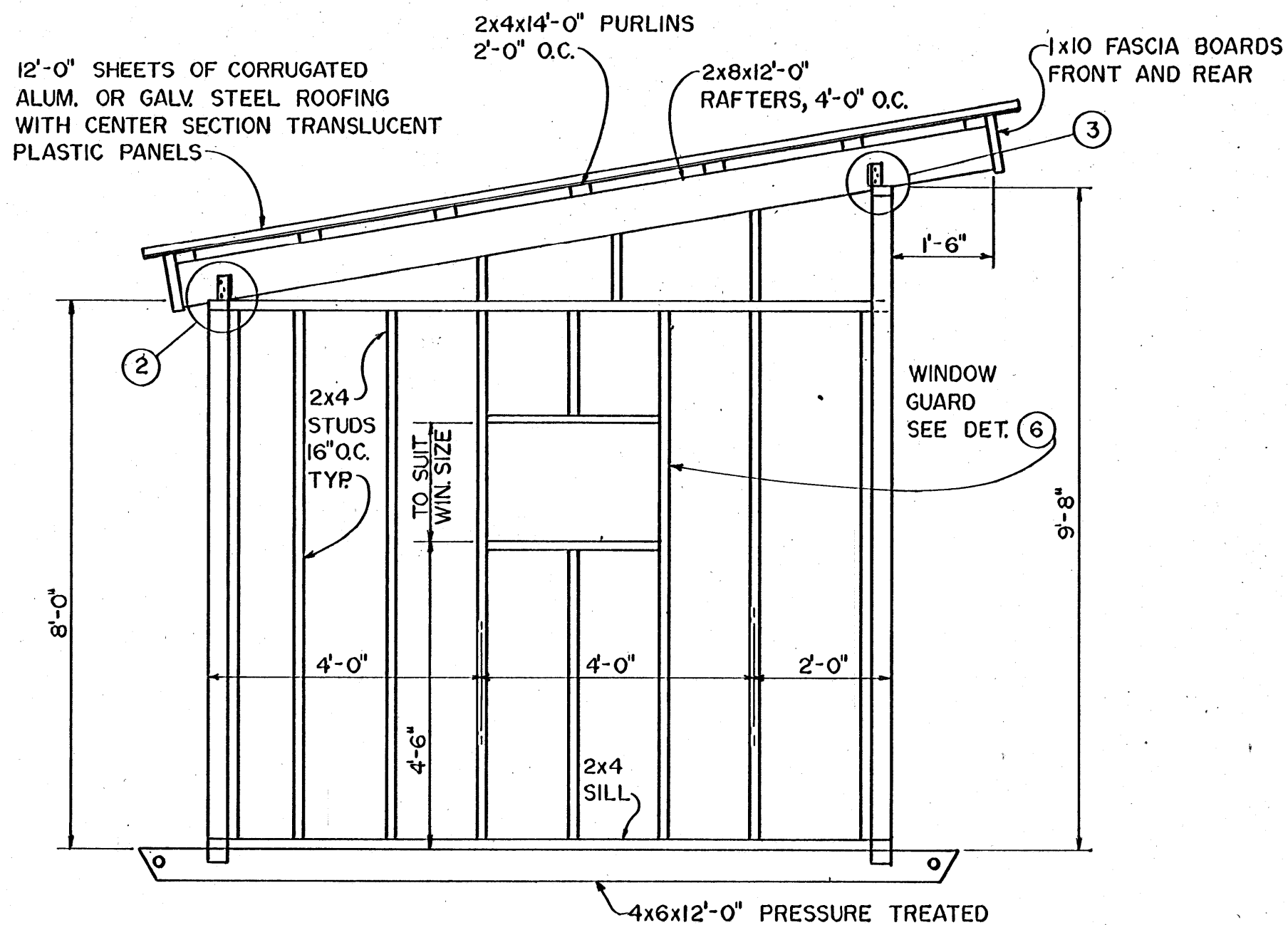

SIDES

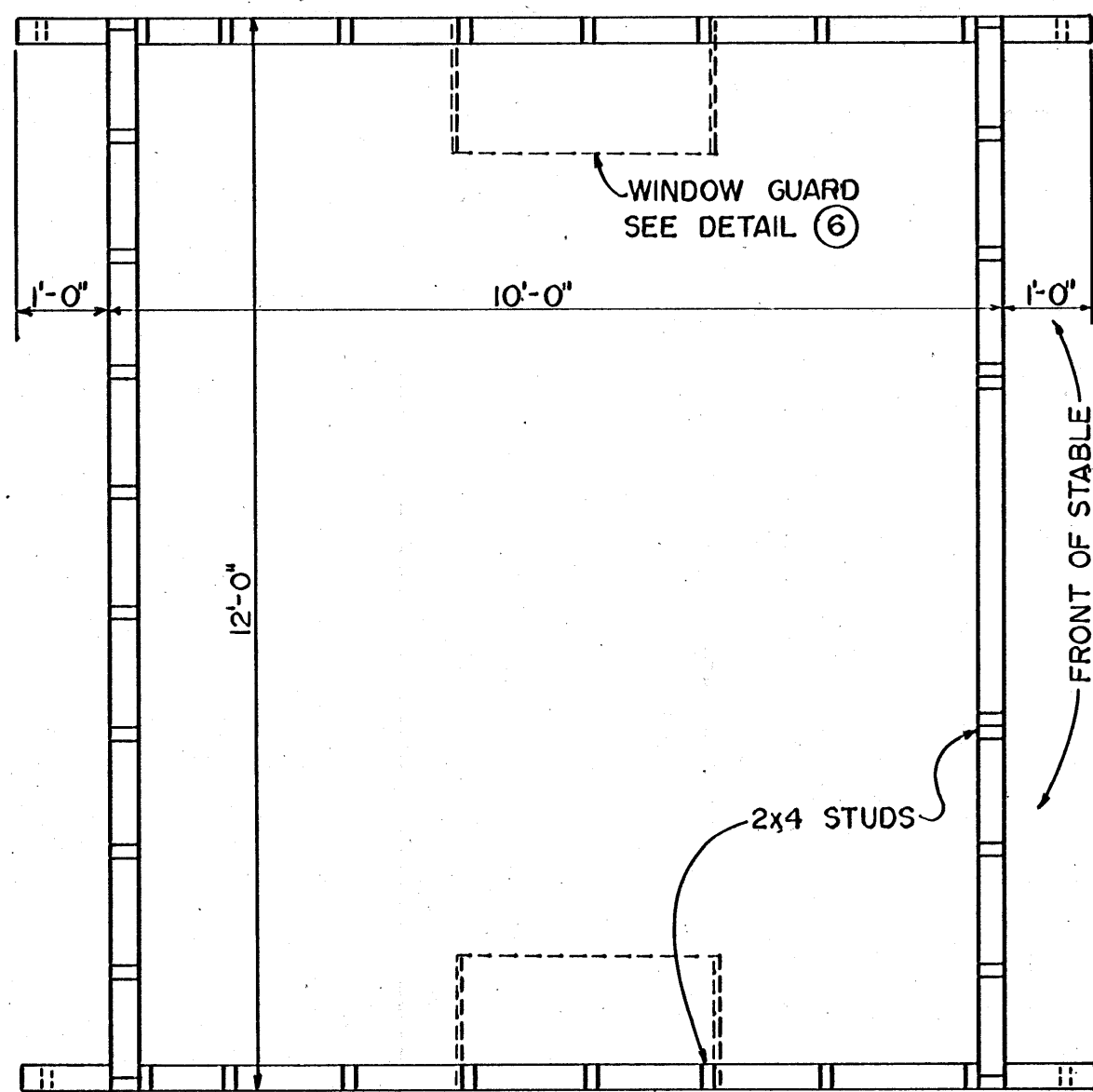

PLAN

MATERIAL LIST

- 6-ALUM. OR GALV. STEEL ROOFING SHEETS (26"x14")
- 1-TRANSLUCENT ROOF SHEET

LUMBER

- 7-2x4x14'-0"
- 4-2x4x12'-0"
- 12-2x4x10'-0"
- 36-2x4x8'-0"
- 4-2x8x12'-0"
- 2-4x6x12'-0" P.T.
- 2-4x6x12'-0" P.T.
- 2-1x10x14'-0"
- 2-1x10x12'-0"
- 5-1x3x10'-0"
- 8-1x4x10'-0"
- 3-3/4x4x8'-0"

MISCELLANEOUS

- 8-COMMERCIAL CONNECTORS
- 1-DOOR (MAT'L AS REQ'D)
- 4-HEAVY DUTY T-HINGES
- 4-3" HINGES FOR REAR OPNG'S
- 2-LATCHES FOR REAR OPNG'S
- 2-16"x32" 3 LITE WINDOWS OPT'L
- NAILS, LAG SCREWS, ETC. AS REQ'D

FRAMING DETAILS

NOTE:
SCALE: 1/2" = 1'-0" UNLESS OTHERWISE STATED

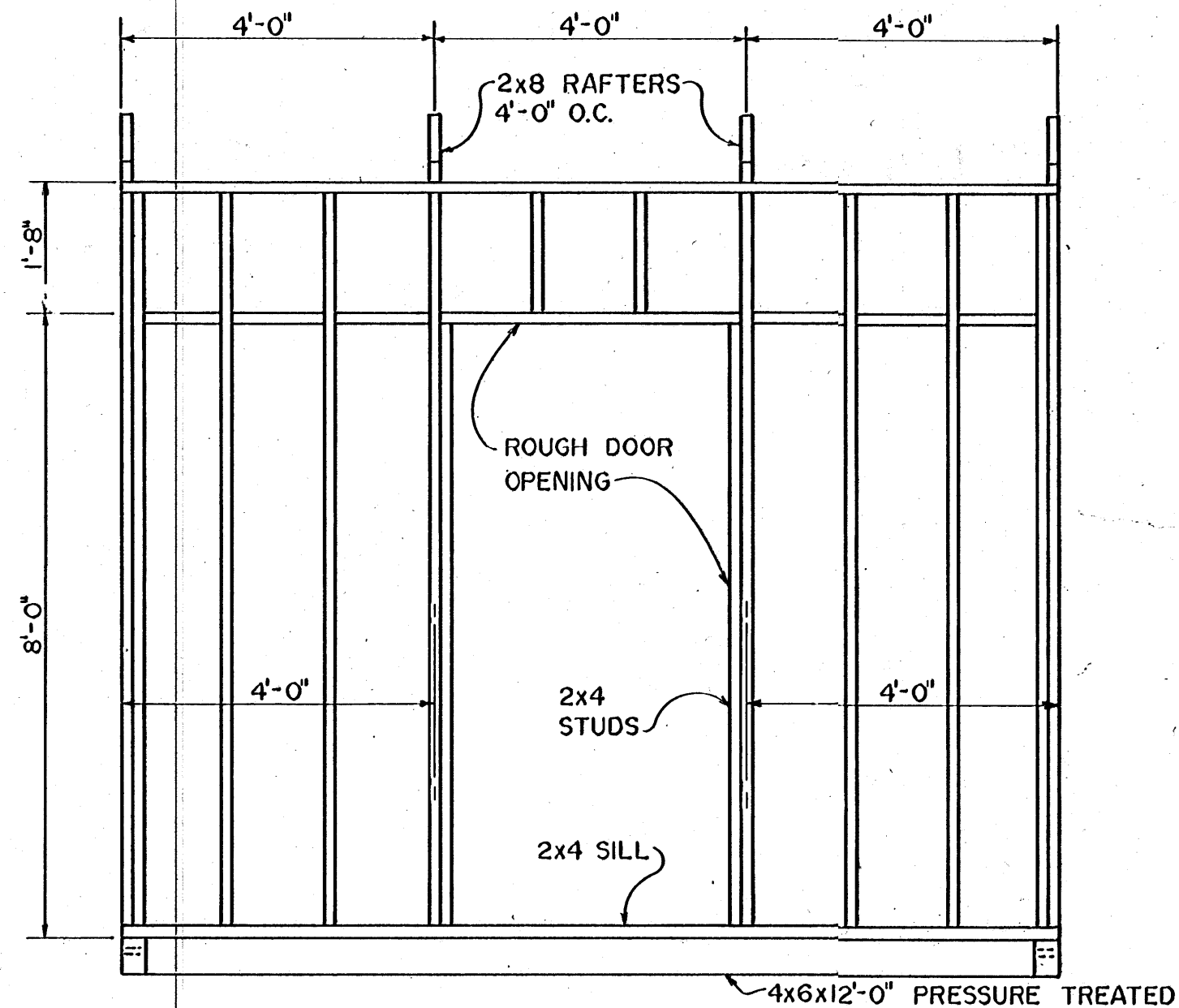

FRONT

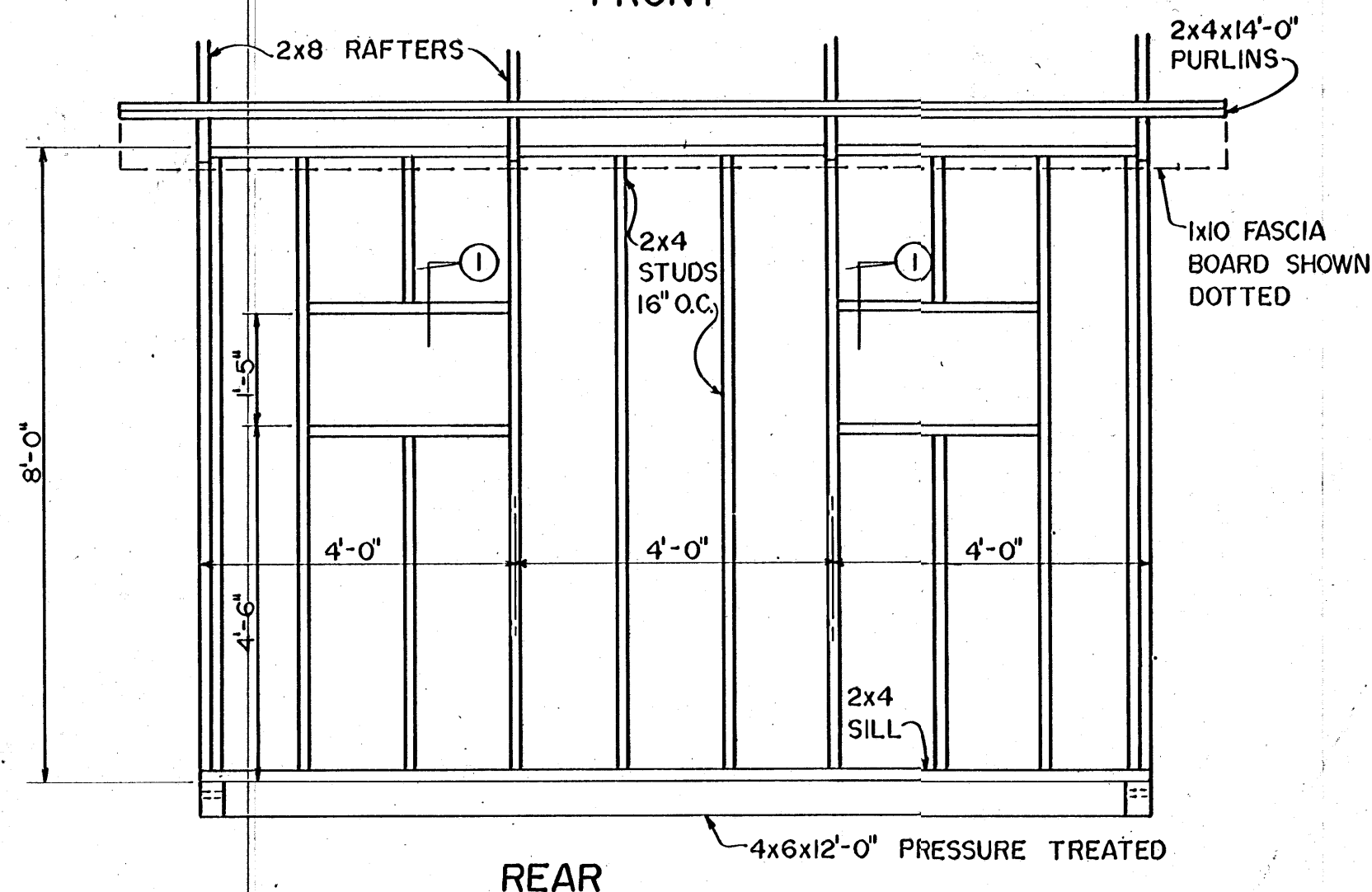

REAR

COOPERATIVE EXTENSION WORK IN AGRICULTURE AND HOME ECONOMICS STATE OF MISSISSIPPI MISSISSIPPI STATE UNIVERSITY AND UNITED STATES DEPARTMENT OF AGRICULTURE COOPERATING		
PORTABLE STABLE FOR A HORSE		
N.J. '69	6082	SHEET 2 OF 2